

LIGHT LIQUID SEPARATOR ECODEPUR[®] OILTECH NS 6

TECHNICAL INFORMATION

ECODEPUR[®] OILTECH NS6 is Light Liquid Separator destined to clean water polluted with light free floating liquids such as engine oils, gas, oil etc, Class 1 in according of EN 858, with double coalescent cell and automatic closure device.



ECODEPUR[®] DEPUROIL[®] Separators has CE marking, in accordance with the legal obligations that stems from the entry into force of the Regulation (UE) N.º 305/2011 of Construction Products, fulfilling all the requisites of the European Standard EN 858-1:2002.

EUROPEAN STANDARD	EN 858-1
EQUIPMENT IDENTIFICATION	Light Liquid Separator
MARCA	ECODEPUR [®]
TYPE	OILTECH NS6
CLASS EN 858-1	Class 1 (<5,0 mg "Mineral Oils"/l ⁽¹⁾)
NOMINAL SIZE	6 l/s
COALESCENT CELL	Double (lamellar/fibrillar)
AUTOMATIC CLOSURE DEVICE	Included (system always calibrated)
VOLUME PRE-SLUDGE TRAP	450 l
OIL STORAGE	940 l
FIRE CLASS REACTION	F
MATERIAL	Polyethylene
VENTE POINT	Included (1 1/2")
COVER	Polyethylene

⁽¹⁾ Teste conditions EN 858-1

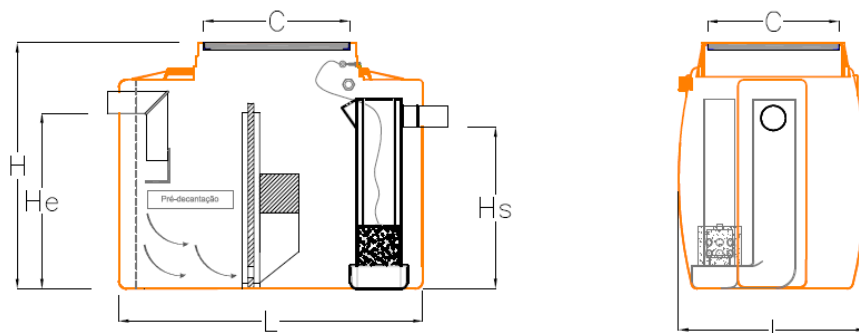

TYPE	NS (l/s)	VOLUME (l)	L (mm)	I (mm)	H (mm)	He (mm)	Hs (mm)	C (mm)	Ø PIPE (mm)
OILTECH NS6	6,0	1.360	1.560	960	1.230	915	805	750 X 750	125

TECHNICAL NOTE: In washing areas, the use of hydrocarbon separators, such as ECODEPUR[®] DEPUROIL[®], is recommended.

Rev.0_16.02.26 | The pictures and dimensions can be changed without notice.